

SNAP™ 200

SNAP 200 offers simple walk-up and measure capability. Simply place the part on the worktable and press GO. SNAP 200 includes

- **Automation Speeds Throughput** – SnapShot identifies and measures features instantly – without programming. Measured results are easily reported and exported.
- **Telecentric Optics** – Ensure accurate measurements across the wide field of view with low distortion – even when not perfectly focused. Zoom Anywhere technology instantly zooms the image anywhere in the wide field of view to measure small features instantly.
- **Simplicity and Value** – OGP dual mag optics, three light sources, a large field metrology camera, and a 250mm X axis make SNAP 200 a strong choice when increased throughput is critical.

Compact, Large Field of View Video Measuring Machine with Motorized X Stage

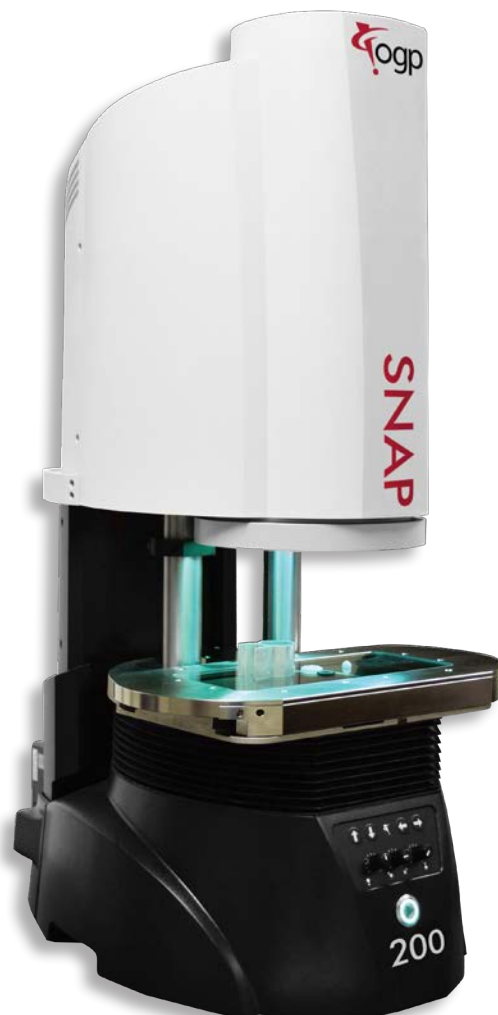

SnapShot™ identifies and measures features of parts in seconds – without programming.

Measurements Made Simple

Choice of SNAP-X or ZONE3 Metrology Software

SNAP™ 200

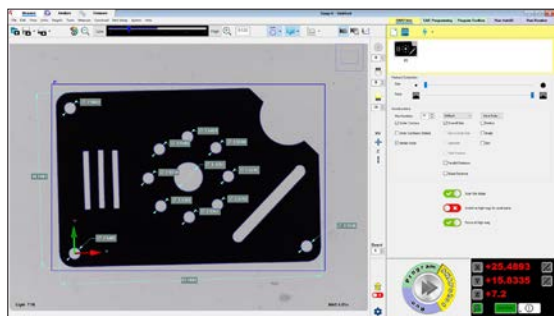

SNAP-X software provides users with a simple, powerful interface for instant 2D measurement and auto program generation. The software also utilizes powerful GD&T based algorithms and point and click feature identification to easily program a wide variety of parts. Virtual chart gaging, profile analysis tools and integrated reporting allow for quick and easy output of measurements.

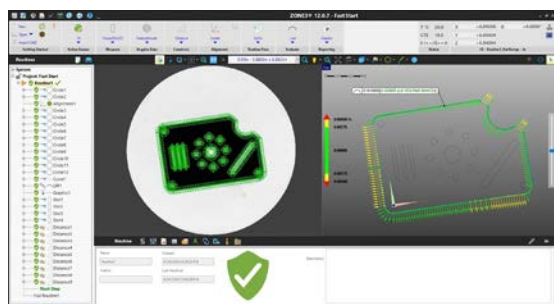

ZONE3 uses innovative features to automatically generate measurement routines resulting in faster programming and run times. Parallel Processing combined with intelligent routine Optimization can be used to measure as many features as can be seen simultaneously.

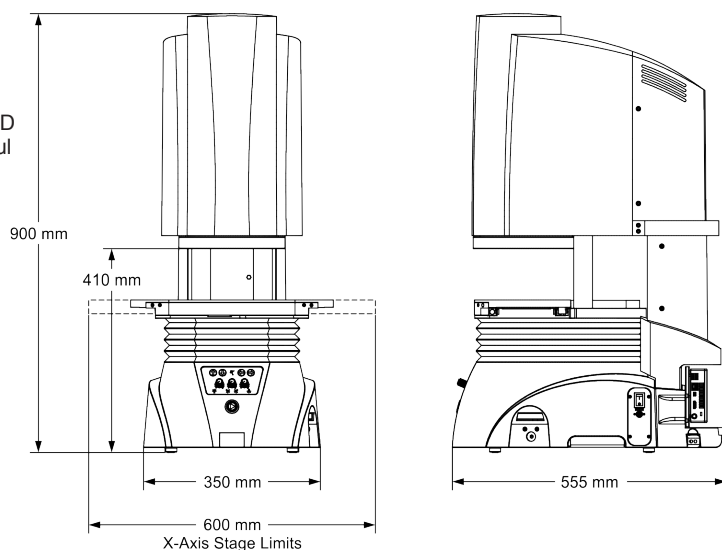

System Weight: 60 kg
Shipping Weight: 120 kg

| | Standard | Optional |
|---|--|---|
| Measuring Unit | Rigid, cast aluminum base and nickel plated worktable; 4 kg load capacity, evenly distributed | |
| Stage | Motorized, programmable 150 mm X and 75 mm Z axis (focus) adjustment with push-button controls | |
| Maximum Measuring Range (X,Y) | 250 mm x 100 mm | |
| Optics | Telecentric, dual optical magnification with 4x high magnification lens | |
| Illumination | All LED and monochromatic. Substage profile light, coaxial square-on surface light and programmable 8-sector oblique ring light | |
| Metrology Camera | Large field megapixel metrology camera | |
| Field of View | Low Mag: 100 mm Ø 4x High Mag: 32 mm x 32 mm | |
| Max Digital Zoom | Low Mag: 42.2 mm x 42.2 mm 4x High Mag: 10.7 mm x 10.7 mm | |
| Depth of Field | Low Mag: 50 mm 4x High Mag: 10 mm | |
| Working Distance | Low Mag: 150 mm 4x High Mag: 150 mm | |
| Controls | GO button, illumination controls, push-button controls for motorized X stage, and toggle switch for Z motion control | |
| Software | Metrology Software: SNAP-X Measure and Compare | Metrology Software: ZONE3 Express, Prime, or Pro in lieu of SNAP-X Productivity Software: SNAP-X Analyze, OGP® EVOLVE® SPC Offline Software: SNAP-X or ZONE3 |
| System Controller | Compact system controller with USB communication ports | Single flat panel LCD monitor, or dual flat panel LCD monitors; keyboard, mouse; USB-Ethernet adapter, system controller with networking and communication ports |
| Accessories | | SNAP Miniature Rotary (SMR) indexer, barcode reader, USB digital I/O capability, fixture kit, calibration artifact |
| Power Requirements | 100-120 VAC or 200-240 VAC, 50/60 Hz, 1 phase, 160 W | |
| Safe Operating Environment | 15-30 °C, non-condensing | |
| Rated Environment | Temperature 18-22 °C, stable to ±1 °C, max rate of change 1 °C / hour, max vertical gradient of 1 °C / meter; 30-80% humidity; vibration <0.001g below 15 Hz | |
| XY FOV Accuracy (E₂) | Low Magnification Lens: (4.0 + L/50) µm 4x High Magnification Lens: (2.0 + L/50) µm | |
| XY Area Accuracy (E₂) | (7.0 + L/50) µm | |

Accuracy is evaluated with a QVI verification procedure where "L" is measured length in millimeters. Specifications apply within the rated environment. Optical specifications apply at the maximum optical and digital magnification of the specified configuration. XY FOV Accuracy applies with an evenly distributed load up to 2.5 kg in the standard measuring plane. The standard measuring plane is defined as perpendicular to the optical axis within 0.5 mm, and within 5.0 mm of best focus.



World Headquarters: Rochester, NY, USA • 585.544.0400 • www.ogpnet.com

OGP Shanghai Co, Ltd: Shanghai, China
86.21.5045.8383/8989 • www.smartscope.com.cn

OGP Messtechnik GmbH: Hofheim-Wallau, Germany
49.6122.9968.0 • www.ogpmesstechnik.de

Optical Gaging (S) Pte Ltd: Singapore • 65.6741.8880 • www.smartscope.com.sg